

Model Number: P830986
Description: 3" Full Range

Revision: rev_2_1
Date: 20-May-09



Peerless Lifestyle full range drivers set the standard for quality audio in products including flat panel televisions and sound bars, MP3 and cell phone docking stations, and multimedia PCs. With their high power handling, smooth, even dispersion and low distortion, the Peerless full range drivers can be paired with the Tymphany LAT250 for great bass performance. Features include: A Neodymium motor structure and doubleventing system that helps keep dynamic range intact, as the transducer can handle more power and dissipate excess heat efficiently. An anodized aluminum dome provides superior sound dispersion and off-axis response. A semi-progressive surround reduces distortion, especially at high output through long excursion. The drivers' direct connected dome dust cap (connected to the magnet system voice coil) improves dispersion at high frequencies, providing superior sound on the high notes. The inserted copper cap on the pole piece ensures control the system impedance, thereby extending the upper frequency range.



Mechanical 2D Drawing:

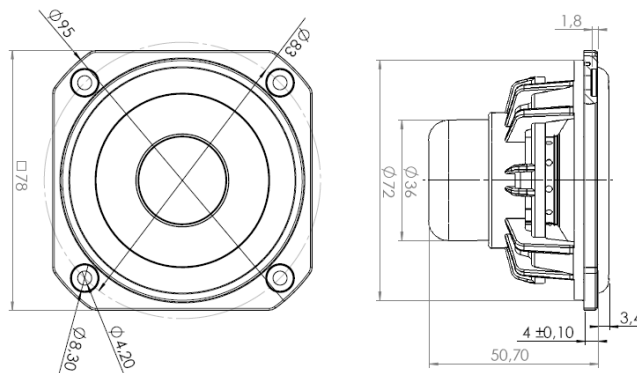

Specifications:

DC Resistance	R_{evc}	Ω	6.0	Energy Bandwidth Product	EBP	$(1/Q_{\text{es}})f_s$	121
Minimum Impedance	Z_{min}	Ω	6.5	Moving Mass	M_{ms}	g	2.52
Voice Coil Inductance	L_e	mH	0.05	Suspension Compliance	C_{ms}	um/N	974.3
Resonant Frequency	f_s	Hz	102	Effective Cone Diameter	D	cm	6.1
Mechanical Q Factor	Q_{ms}	-	4.6	Effective Piston Area	S_D	cm ²	28.9
Electrical Q Factor	Q_{es}	-	0.84	Equivalent Volume	V_{as}	L	1.25
Total Q Factor	Q_{ts}	-	0.71	Motor Force Factor	BL	T·m	3.39
Ratio f_s / Q_{es}	F	f_s / Q_{es}	143	Motor Efficiency Factor	β	$(T \cdot m^2) / \Omega$	1.91
Half Space Sensitivity @ 2.83V	$\text{dB} @ 2.83\text{V}/1\text{m}$	dB	84.8	Voice Coil Inner Diameter	VC_d	mm	25.7
Rated Noise Power (IEC 2685 18.1)	P	W	12	Maximum Linear Excursion	X_{max}	mm	2.05
Test Spectrum Bandwidth	100 - 8000	12 dB/Oct		Voice Coil Former Material	VC_{m}	-	ASV
				Transducer Mass	-	kg	0.208

Frequency and Impedance Response:

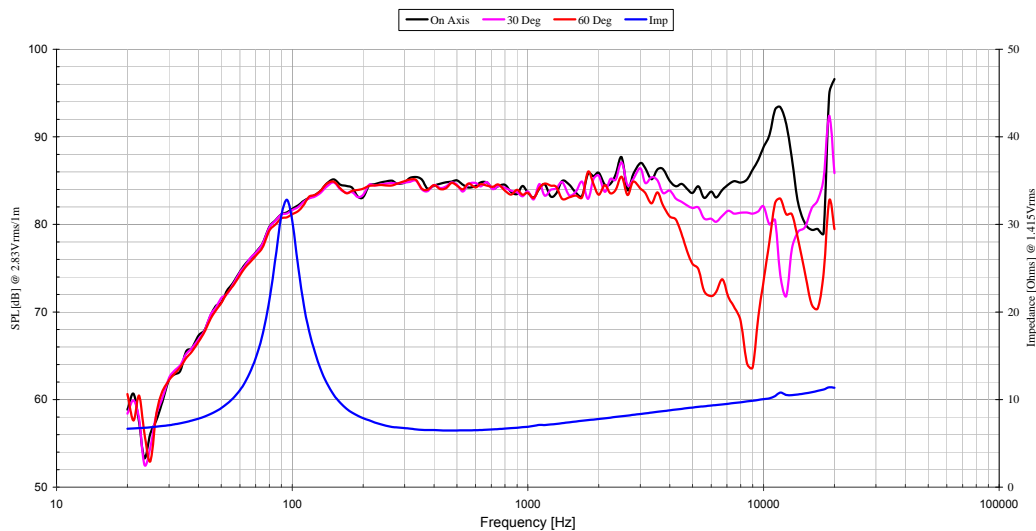

F088-0713A